

172x150x51mm (6.77"x5.90"x2.00")



Frame: Aluminum Alloy  
 Impeller: UL94V-0 Reinforced Plastic  
 Lead wire: UL 1007AWG24  
 Red wire positive (+)  
 Black Wire negative (-)  
 Operation Temperature: -10°C-70°C  
 Motor Protection: Impedance Protected  
 Reverse Polarity Protected  
 Safety approval: UL TUV CE

Specifications(Nominal)

S=Sleeve bearing

D=Two ball bearing

Model No.	Bearing System Type	Rated Voltage (VDC)	Speed Type	Rated Current (A)	Rated Speed (RPM)	Air Flow (CFM)	Aire Pressure (mmAg)	Noise Level (dBA)	Weight (g)
HT□D17251	S/D	12	M	1.20	3000	238.20	11.75	50.0	700
		24	M	0.80	3000	238.20	11.75	50.0	
		48	H	0.45	3300	262.10	14.66	55.0	
			M	0.36	3100	258.00	13.46	51.0	

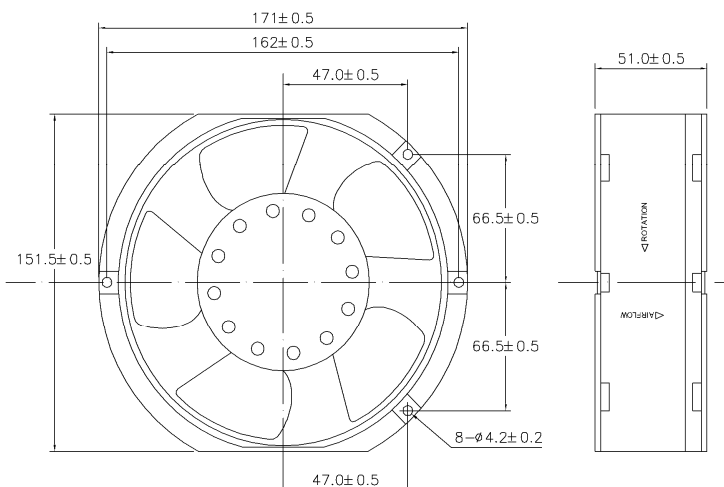

\* All reading are typical values at rated voltage.  
 \* Specifications subjected to change without notice